

WABCO

Technical Bulletin

Testing Electronically Controlled Air Dryers (ECAD) Independent of Other Vehicle Systems

Hazard Alert Messages

Read and observe all Warning and Caution hazard alert messages in this publication. They provide information that can help prevent serious personal injury, damage to components, or both.

⚠ WARNING

To prevent serious eye injury, always wear safe eye protection when you perform vehicle maintenance or service.

Park the vehicle on a level surface. Block the wheels to prevent the vehicle from moving. Support the vehicle with safety stands. Do not work under a vehicle supported only by jacks. Jacks can slip and fall over. Serious personal injury and damage to components can result.

Release all air from the air systems before you remove any components. Pressurized air can cause serious personal injury. Refer to the vehicle manufacturer's service manual for instructions.

How to Obtain Additional Maintenance, Service and Product Information

If you have any questions regarding the material covered in this bulletin, or for information about the WABCO product line, please contact the WABCO Customer Care Center at 855-228-3203 or visit our website:

wabco-na.com

Tools and Supplies Required

- Air gauge — 200 psi (13.8 bar) minimum
- Power supply — 12 volt
- Air supply — 120-140 psi (8.27-9.7 bar) with shut-off valve
- Air tank — one gallon (3.8 l) minimum
- Multimeter (Volt/Ohm meter)

Testing the Electronically Controlled Air Dryer

This technical bulletin provides a procedure for testing the electronically controlled air dryer (ECAD), part number 4324252000, independently of other vehicle systems. It is not intended to replace existing service diagnostic and repair procedures.

If the air dryer does not pass any of the tests described in the following procedure, you must record the result and contact the WABCO Customer Care Center at 855-228-3203.

1. Disconnect the ECAD solenoid electrical 4-way connector from the air dryer. Figure 1.

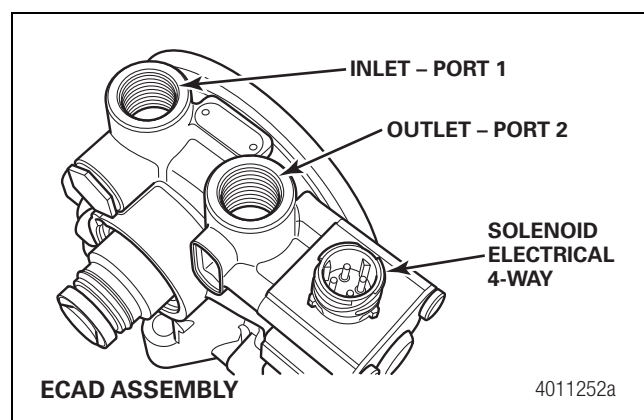

Figure 1

2. Check for water contamination and physical damage to the electrical pins on both the ECAD solenoid electrical 4-way and on the vehicle's wiring harness 4-way connector.
3. Connect the Test Wire Harness 4-way connector to the ECAD solenoid electrical 4-way.
4. Use a volt/ohm meter to test solenoid resistance as follows. Select electrical resistance (Ω Ohm), and set the scale according to the range values measured in the following steps. Figure 2 and Figure 3.

- A. Test between brown test lead Pin 1 and red test lead Pin 4. The measured resistance should be within the range of 12.5-14.3 Ohms.
 - B. Test between green test lead Pin 3 and red test lead Pin 4. The measured resistance should be within the range of 18.2-20.2 Ohms.
 - C. Test between red test lead Pin 4 and ECAD valve body for ground. The measured resistance should be open (OL).
- **If the resistance in any of the tests is not within specification:** Stop further testing and call the WABCO Customer Care Center at 855-228-3203.

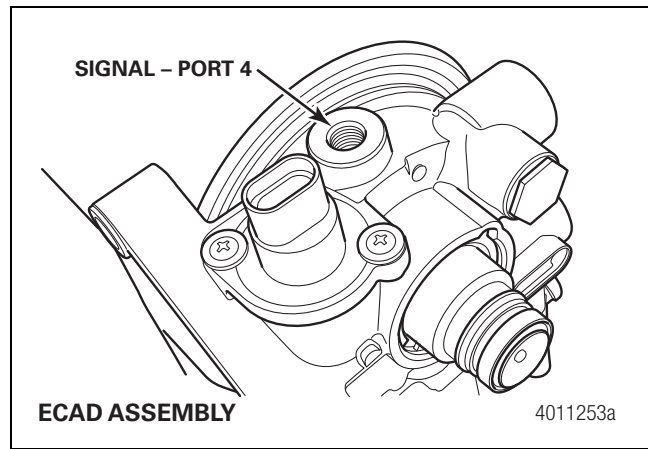

Figure 4

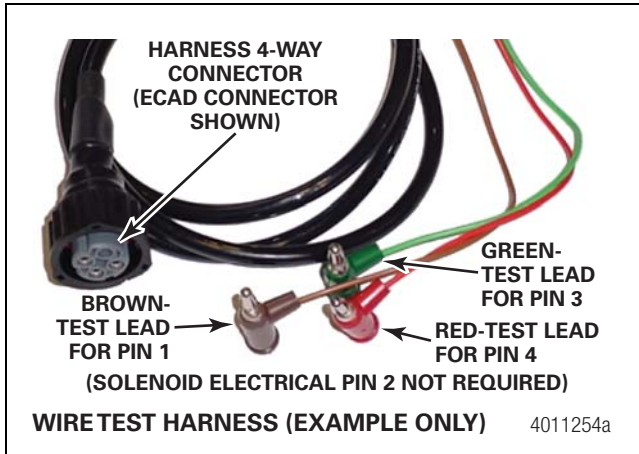

Figure 2

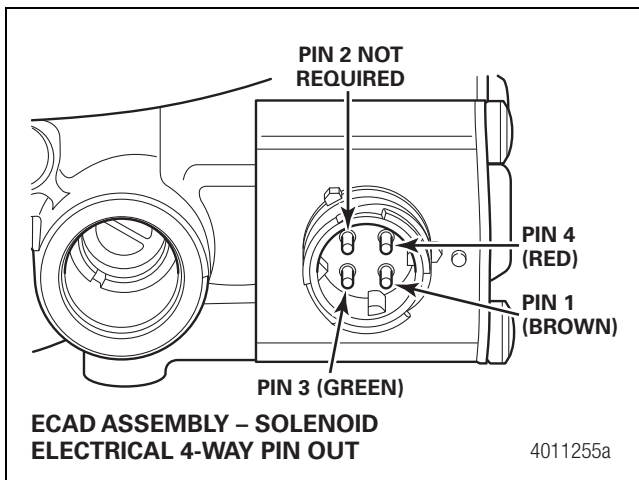

Figure 3

5. Disconnect the air dryer inlet (port 1), signal (port 4) and outlet (port 2) lines. Figure 1 and Figure 4.

6. Connect shop air with a closed shut-off valve to the inlet (port 1). The shut-off valve should be mounted between the air supply and ECAD inlet (port 1).
7. Connect an air gauge to signal (port 4).
8. Connect a one-gallon (3.8 l) or larger air tank to the dryer outlet (port 2).
9. Open the inlet valve supplying shop air to the dryer and verify the following.
 - There are no air leaks from the dryer.
 - The air tank fills with air.
 - The signal gauge does not move.
10. Close the inlet valve and supply 12 volts to red test lead Pin 4 of the solenoid and ground test lead Pin 3, then verify the following.
 - The dryer purges, then stops leaking.
 - The signal gauge rises to the tank pressure.
11. Remove the ground from green test lead Pin 3, then verify that the signal gauge falls to 0 psi.
12. Ground green test lead Pin 3 and brown test lead Pin 1 of the solenoid connector (with 12 volts on red test lead Pin 4 still in place) and verify the following.
 - The tank drains through the purge valve slowly (desiccant regeneration). The purge valve will close at its minimum setting, retaining some pressure on the air gauges, generally around 35-70 psi (2.41-4.8 bar). This is normal.
13. If the dryer passes the above tests, the dryer is functioning correctly. Replace the connections to the air dryer and return to service.

If the air dryer did not pass any of the tests, record the results and call the WABCO Customer Call Center at 855-228-3203.

WABCO

WABCO North America
1220 Pacific Drive
Auburn Hills, MI 48326 USA
855-228-3203
wabco-na.com

Information contained in this publication was in effect at the time the publication was approved for printing and is subject to change without notice or liability. WABCO reserves the right to revise the information presented or to discontinue the production of parts described at any time.

Copyright 2018
WABCO, Inc.
All Rights Reserved

Printed in USA

TP-1474
Revised 10-18
(16579)