

WABCO

Technical Bulletin

Trailer ABS In-Line Filter Valve and Gladhands with Integral Filters

Hazard Alert Messages

Read and observe all Warning and Caution hazard alert messages in this publication. They provide information that can help prevent serious personal injury, damage to components, or both.

⚠ WARNING

To prevent serious eye injury, always wear safe eye protection when you perform vehicle maintenance or service.

Release all pressure from the air system before you disconnect any components. Pressurized air can cause serious personal injury.

Park the vehicle on a level surface. Block the wheels to prevent the vehicle from moving. Support the vehicle with safety stands. Do not work under a vehicle supported only by jacks. Jacks can slip and fall over. Serious personal injury and damage to components can result.

In-Line Filter Valve

Installation Guidelines

For installation related to gladhands, refer to Gladhands with Integral Filters.

Install the in-line filter valve in the air line before the brake valves in the control line, or in both the control and supply lines as illustrated in Figure 1. The valve may also be nipple mounted to the gladhand.

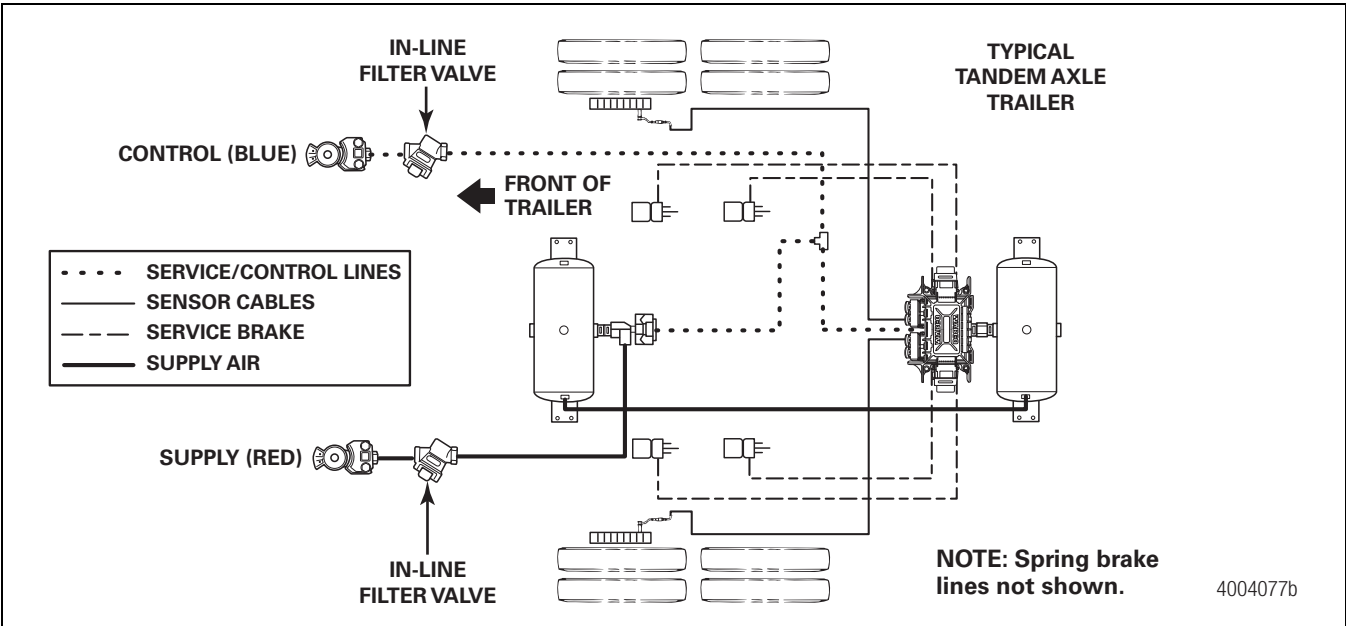

Figure 1

Mounting Requirements

Install the valve with the filter portion facing **DOWNWARD** so that the air line ports are horizontal. Figure 2.

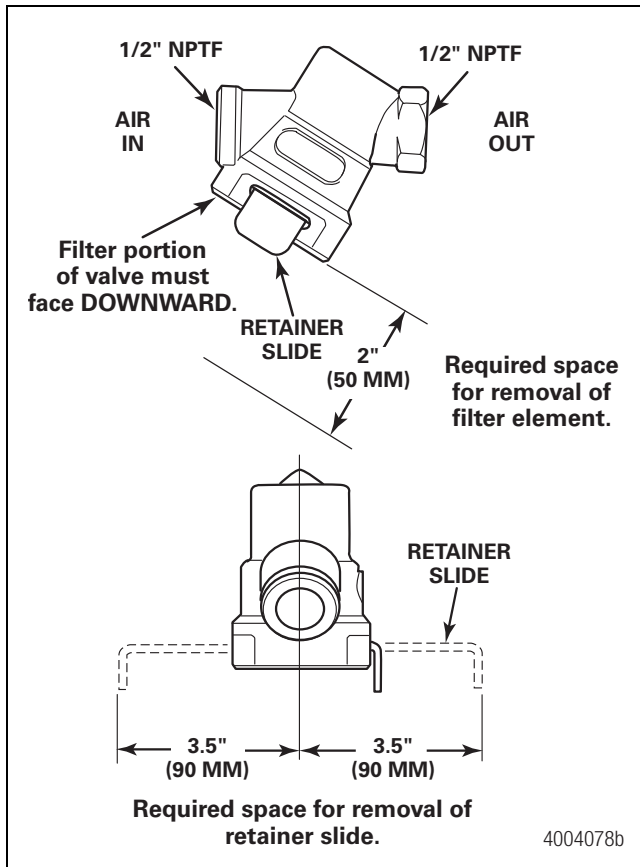

Figure 2

Allow sufficient clearance:

- Minimum of 3.5 inches (90 mm) to release the retainer slide bar
- Minimum of two inches (50 mm) for removal and installation of internal components
- Use 1/2-inch NPTF port fittings

Use a bracket and clamp to support the in-line filter valve. Figure 3.

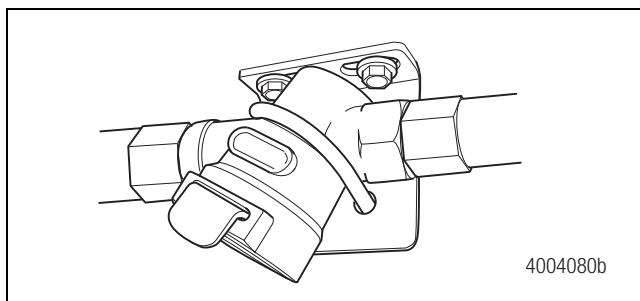

Figure 3

Maintenance Guidelines

For complete maintenance and service instructions for WABCO products, visit our website, www.wabco-auto.com.

If you require technical assistance, contact WABCO North America Customer Care at 855-228-3203.

General Maintenance

Inspect and clean the internal filter screen every three to four months, more frequently for severe applications where dirt and dust levels may be excessive. Figure 4.

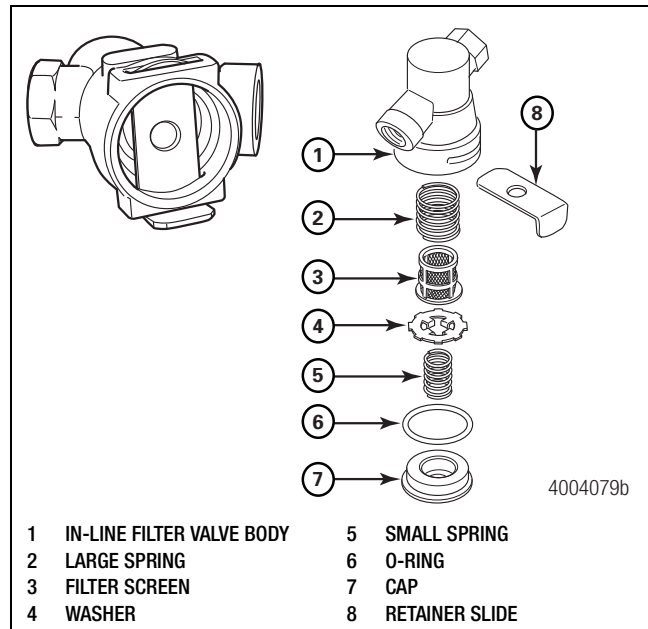

Figure 4

1. Remove the internal filter screen. Refer to the instructions in the Replacing Internal Components section.
2. Use compressed air to clean dust and debris from the filter and other internal components, or wash with mild detergent and water.
3. Replace any damaged filter screens. If you are replacing only the filter screen, do not discard the large spring, washer, small spring, cap or retainer slide. These are needed for reassembly. Discard the filter screen and O-ring.

Replacing Internal Components

Removing Internal Components

1. Park the vehicle on a level surface and block the wheels to prevent the vehicle from moving.
2. Discharge all pressure from the air system.
3. Remove the retainer slide from the bottom of the in-line filter valve. Hold one hand under the valve cavity to prevent the internal components from dropping to the ground.

- Carefully remove the remaining components. If you are replacing only the filter screen, do not discard the large spring, washer, small spring, cap or retainer slide. These are needed for reassembly. Discard the filter screen and O-ring.
- Inspect and clean the valve bore and the internal components to be used for reassembly. If the bore is damaged so that a tight seal cannot be maintained, replace the entire in-line filter valve.

Installing Internal Components

Insert the clean internal components into the valve bore as follows:

- Large spring
- Filter screen
- Washer
- Small spring
- O-ring
- Cap
- Retainer slide

Removing the In-Line Filter Valve

- Park the vehicle on a level surface and block the wheels to prevent the vehicle from moving.
- Discharge all pressure from the air system.
- Disconnect the air lines.
- Remove the in-line filter valve from its mounting location.

For assistance, contact WABCO North America Customer Care at 855-228-3203.

Gladhands with Integral Filters

All commercial trailers with air brakes have two connections at the front of the trailer for control and supply air lines. Figure 5. The couplings for these connections are called “gladhands.” While the right and left gladhands may look the same, they are not. They are painted different colors for quick identification and they have mechanical detents to prevent a mismatch when connecting the trailer to the cab.

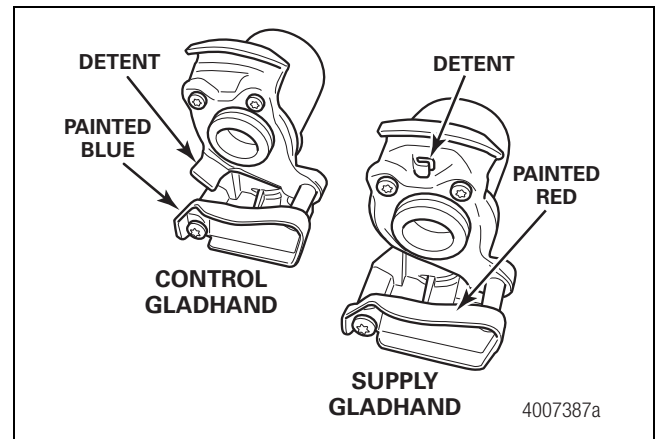

Figure 5

Part number 952 201 018 0 serves the supply air circuit. It is painted RED. It is always mounted on the right side of the two connections as viewed facing the front of the trailer. The supply air line fills the air tank and releases the trailer park brakes when the red trailer knob inside of the tractor’s cab is pushed. This action allows the trailer to be moved.

Part number 952 201 019 0 serves the control air circuit. It is painted BLUE. The operator applies air to the control line in one of two ways: by depressing the brake pedal or by moving the hand control valve. Either of these actions actuates the trailer service brakes.

Installation Guidelines

Each gladhand has a female 1/2-inch NPTF threaded port. Figure 6.

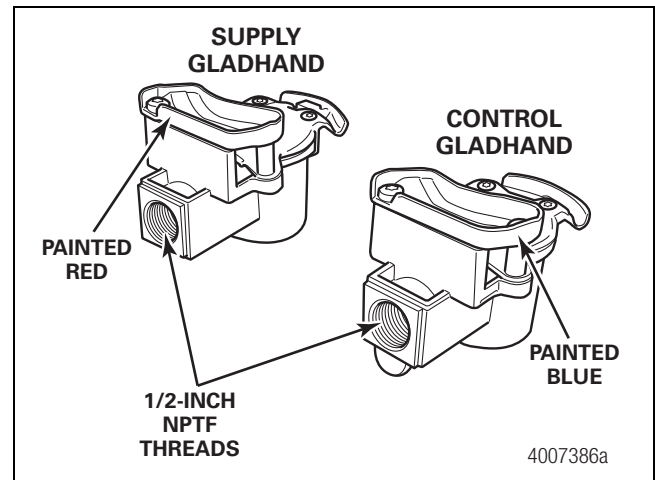

Figure 6

To install a gladhand:

- Apply the recommended NPTF thread sealer to the nipple threads. Apply SAE-standard, DOT-approved Teflon tape or paste-type thread sealant to all pipe threads beyond the first two threads. Pipes with pre-applied thread sealant may also be used.

2. Assemble the gladhand on the air line nipple and hand tighten.
3. Using a wrench, tighten the gladhand an additional 1-1/2 turns or until it is leak-free and positioned to permit the mating gladhand to be attached easily.

Maintenance Guidelines

Inspect and clean the internal filter screen every three to four months, more frequently for severe applications where dirt and dust levels may be excessive. Figure 4.

Gladhand Filter Maintenance

1. Park the vehicle on a level surface and block the wheels to prevent the vehicle from moving.
2. Discharge all pressure from the air system.
3. Using a 10 mm hex wrench, press and rotate the filter cap 1/4 turn (can be either CLOCKWISE or COUNTERCLOCKWISE). Figure 7.

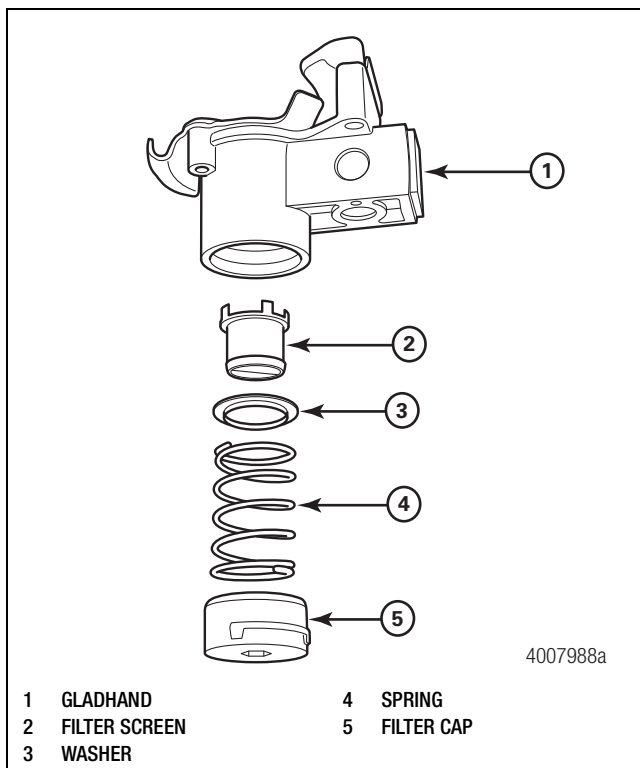

Figure 7

4. Remove the filter cap and spring.
5. Remove the filter screen and washer. If necessary, use a dowel to gently press the filter out through the hole in the coupling side of the gladhand.
6. Clean the gladhand housing and loose parts using compressed air or a mild detergent. Be careful to not allow loose dirt to enter the threaded port area of the gladhand.
7. Install the loose parts into the gladhand housing. Refer to Figure 7 for the order of components. Be sure that the washer is installed correctly. Note that the lip follows the side of the filter screen. Figure 7, item 3.
8. Press the filter cap and spring into the gladhand body. Using a 10 mm hex wrench, rotate the filter cap 1/4 turn to lock into place.

Replacing Internal Components

Individual replacement components are not available. Due to the relatively low cost of a complete gladhand assembly with filter, the assembly should be replaced when an individual part is worn or damaged.

Removing the Gladhand with Integral Filter

1. Park the vehicle on a level surface and block the wheels to prevent the vehicle from moving.
2. Discharge all pressure from the air system.
3. Disconnect the air lines.
4. Remove the in-line gladhand assembly from its mounting location at the front of the trailer.

For assistance, contact WABCO North America Customer Care at 855-228-3203.

WABCO

WABCO North America
2770 Research Drive
Rochester Hills, MI 48309 USA
855-228-3203
wabco-auto.com

Information contained in this publication was in effect at the time the publication was approved for printing and is subject to change without notice or liability. WABCO reserves the right to revise the information presented or to discontinue the production of parts described at any time.

Copyright 2018
WABCO, Inc.
All Rights Reserved

Printed in USA

TP-03100
Revised 07-18
(16579)